



# COMPANY PROFILE



Your One-Stop Global Energy Supply Partner

# ACTOM

SINCE 1903

# The history of John Thompson

We are proud of our history which goes back to the Industrial Revolution of 19th century England.



Since then the company's product development has progressed into economic-type boilers, into watertube boilers and from there into steam generators for fossil fuel-fired and nuclear power stations.

- 1824** William Thompson set up a business near Bilston in the north of England, to build iron boats.
- 1870** This business moved to Wolverhampton and five years later branched out into the manufacture of Lancashire boilers.
- 1935** John Thompson (Wolverhampton) came to South Africa through an agency agreement.
- 1937** UK parent established John Thompson (South Africa) (Pty) Ltd when the company operated as a sales and contracting organisation.
- 1946** the parent company took full control of the South African operation, established its own offices and undertook its own installation and erection work for its industrial boilers.
- 1954** in a merger with local company Albert de Jong (Pty) Ltd, the first John Thompson boiler was manufactured at its plant near Cape Town.
- 1960** John Thompson Africa (Pty) Ltd was established under the control of the UK parent.
- 1969** with the acquisition of Cochran Boilers, another long-established business, the John Thompson- Cochran Group became Europe's leading manufacturer of shell boilers.
- 1970** Clarke Chapman, UK, merged with John Thompson and created the Thompson-Cochran Boiler Division.
- 1977** Clarke Chapman and Reyrolle Parsons formed Northern Engineering Industries.
- 1989** NEI merged with Rolls-Royce to create the Rolls-Royce Industrial Power Group, which included John Thompson Africa and International Combustion Africa Ltd.
- 2001** With the acquisition of NEI Africa Ltd by Alstom South Africa, John Thompson Africa became a business division of Alstom Power with a new name – John Thompson Boilers.
- 2009** Alstom South Africa, which previously shared its name and logo with the Alstom group, rebranded itself with a new name and corporate identity – ACTOM. John Thompson then became a division of ACTOM (Pty) Ltd.
- 2014** John Thompson took over ACTOM's Air Pollution Control division. Also in this year, a major expansion of its works near Cape Town marked John Thompson's 60th anniversary of boiler manufacture in South Africa.

Our certification includes:



# John Thompson today

Serving the global industrial and power generation markets.

Today, John Thompson is a division of ACTOM (Pty) Ltd, a level 1 B-BBEE Contributor with 59.65% Black Ownership and 35.63% Black Women Ownership. It is the largest manufacturer, solution provider, repairer, maintainer and distributor of electro-mechanical equipment in Africa, offering a winning and balanced combination of manufacturing, service, repairs, maintenance, projects and distribution through its 33 outlets throughout Sub-Saharan Africa.

John Thompson is a leading designer and manufacturer of industrial boilers and associated plant with a name synonymous with well-engineered boilers. As well as related products incorporating heat transfer technology, we also design, supply, install and retrofit new and existing environmental equipment and provide boiler service and maintenance for large Utility Boilers and Boiler Ancillary equipment.

The company comprises five business units, namely: Package Boilers, Industrial Watertube Boilers, Utility Boilers & Environmental, Manufacturing and Air Pollution Control – all supported by Technical, Financial, HR, Business Development and Quality Assurance departments.

## Package Boilers

(pages 4, 5 and 14)

Our Package Boilers business unit designs, installs, maintains and services firetube boilers with steam outputs up to 40 t/h and pressures up to 32 bar. These include coal- and biomass-fired boilers with chaingrate stokers, woodfired boilers with fixed grates, oil- and gas-fired boilers and custom designed waste-heat boilers. Its energy management department specialises in the supply of heat energy in the form of process steam, the operation and maintenance of all boiler plant and the supply of fuel, water treatment and waste removal.

## Industrial Watertube

Boilers (pages 6 and 7)

Our Industrial Watertube Boilers business unit designs, installs, maintains and retrofits boilers, which are suitable for cogeneration, with steam outputs, pressures and temperatures up to 350 t/h, 110 bar and 540 °C respectively.

These include coal-fired boilers with travelling grate and CAD spreader stokers and biomassfired boilers with CAD spreader stokers for dual-fuel firing as well as pinhole and dump grates, industrial oil- and gasfired boilers and waste-heat boilers.

## Utility Boilers and Environmental

(pages 8 and 9)

Our Utility Boilers and Environmental business unit services, maintains and retrofits power generation equipment, including coal-milling plant and pulverised fuel systems.

We also design, supply, install and retrofit emission control plant for boilers from 200 MW to 600 MW capacity.

## Manufacturing

(pages 10 and 11)

Our works, located near Cape Town, is listed by Lloyd's Register of Industrial Services as an approved manufacturer of Class 1 fusion welded pressure vessels and we

were the first company in Africa to be certified by the ASME. We have manufactured over 4 500 boilers and pressure vessels for local and export markets.

Our foundry produces castings under the Meehanite process.

## Air Pollution Control

(pages 12 and 13)

For the industrial, mining and mineral sectors, our Air Pollution Control business unit designs, manufactures, supplies, installs and commissions equipment ranging from turnkey engineered systems to unit dust collectors. Products include reverse pulse bag filters, reverse air baghouses, wet scrubbers and cyclones, shaker type and silo vent filters, pressurisation units and dust suppression systems.

## Quality

Across all five business units we maintain an internationally certified Quality Management System based on ISO 9001: 2015. In addition, our Environmental Management System is certified to ISO 14001 : 2015 and our Welding Quality Assurance is certified to ISO 3834. Coupled with our expertise, this ensures that we enjoy successful business relationships with local and international customers.

For product brochures and case studies, please visit our website: [www.johnthompson.co.za](http://www.johnthompson.co.za)



Redipac biogas-fired boiler

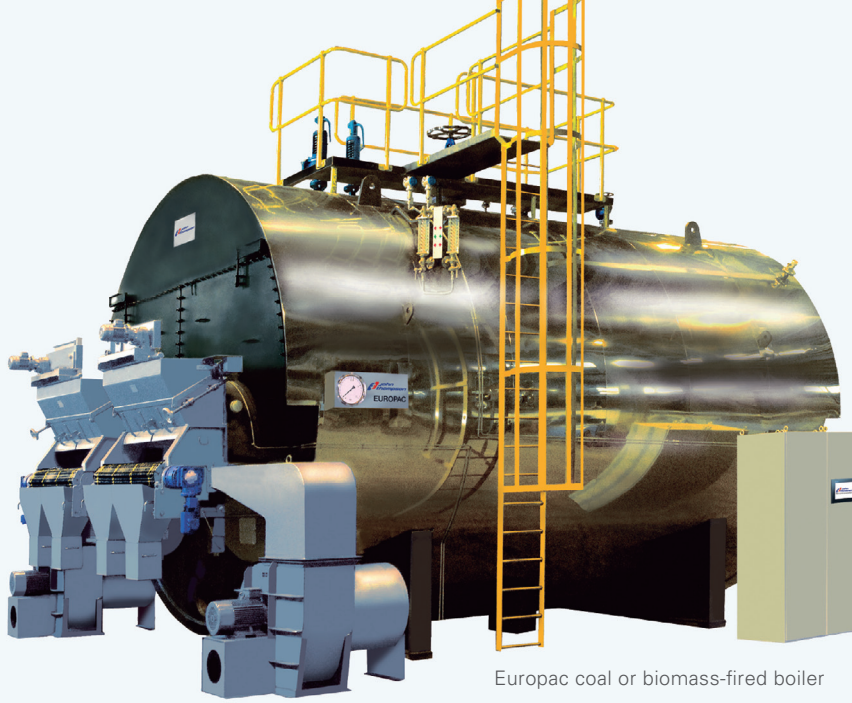

Europac coal or biomass-fired boiler

## Package Boilers

Our Package Boilers business unit is led by a dedicated team of engineers with many years' experience in the steam industry. Our business is based on internationally competitive technology, price and delivery, and provides the full spectrum of boilers and steam services to our customers in a variety of industries in both national and international markets. Our network of representatives in Africa, South-East Asia, the Middle-East, South America and Australia provide the necessary after-sales support and services.

### Boiler designs

Our firetube shell boiler designs include:

- oil- and gas-fired boilers
- wood-fired boilers with fixed grates
- custom-designed waste-heat boilers
- coal- and biomass-fired boilers with chaingrate stokers

All boilers are designed and manufactured in accordance with the latest European Standard, EN12953.

Our latest spiral-tube technology is used throughout the boiler ranges. With heat transfer up to 100 % greater than normal plain tubes this

feature reduces the flue-gas outlet temperature to only 15°C above steam saturation temperature.

Our Micropac energy management system is a feature on our Europac coal and biomass-fired boilers as it increases efficiency and reduces operating and maintenance costs significantly.

Our Enviropac and Redipac oil- and gas-fired boilers are supplied with renowned combustion controllers as standard.

### Boiler ranges and outputs

<b>Enviropac</b>	Oil- and gas-fired	5 000 to 40 000 kg/h
<b>Europac</b>	Coal- and biomass-fired	1 800 to 21 000 kg/h
<b>Redipac</b>	Oil- and gas-fired	1 000 to 5 000 kg/h
<b>Simpac</b>	Wood-fired	3 000 to 6 000 kg/h
<b>Aquagen</b>	Coal-fired	1 100 to 6 500 kW
<b>Torripac</b>	Biomass-fired	1 000 to 13 000 kg/h

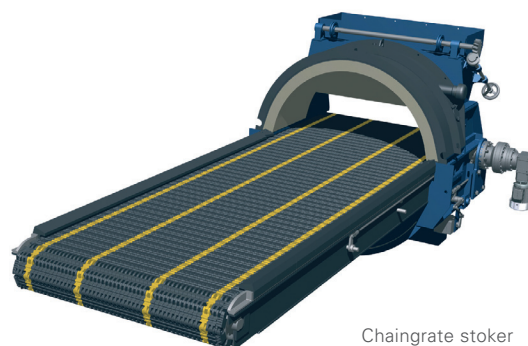

Chaingrate stoker



Enviropac oil or gas-fired boiler



Simpac wood-fired boiler

### Package boiler services

- Technical support
- Steam outsourcing
- Turnkey installation
- Project management
- Fluent CFD modelling
- Caesar II pipe stressing
- Commissioning and testing
- After sales service and spares
- Audits and efficiency upgrades
- Autocad Inventor 3D modelling
- Operator and supervisor training
- Boiler and metallurgical inspections
- Boilerplant and energy management
- Boiler thermal modelling and design
- Coal / Oil / Gas / Biomass conversions
- Retrofit, overhaul, repair and maintenance

### Customer service and support

Our service engineers regularly visit countries where our boilers are installed to support our agents and customers.

An extensive range of OEM spares is available for all of our products. Also, our works has the capacity to cater for urgent breakdowns and can manufacture pressure part spares for our equipment to the latest design codes.

### Upgrades

For improved boilerplant efficiency either through increased steam output or a reduction in fuel usage, we offer customers on-site advice and upgrading solutions.

We can retrofit our spiral-tubes, latest chaingrate stokers, improved flue-gas emission control plant and modern control systems to improve boiler performance and reduce operating costs.

Our boilers are designed to facilitate conversions when there is a need to change from coal-fired to biomass-, oil-, gas or dual-fuel fired. Engineered solutions are also offered so that conversions can be carried out on site with minimum downtime.

### Training

Our Boiler Development and Training Centre staff provide the skills required for the efficient operation of modern boilerplant.

On-site training is available for customers who want specific training on their own plant.

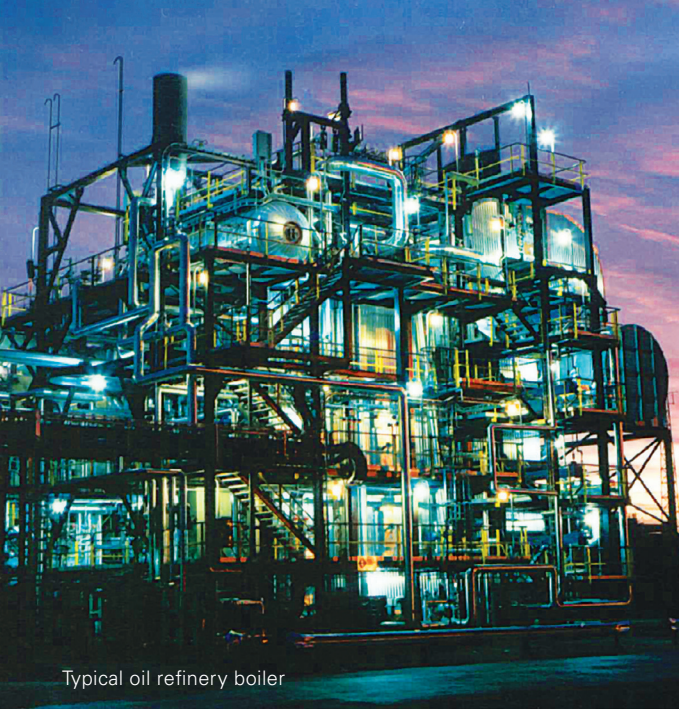

Typical oil refinery boiler

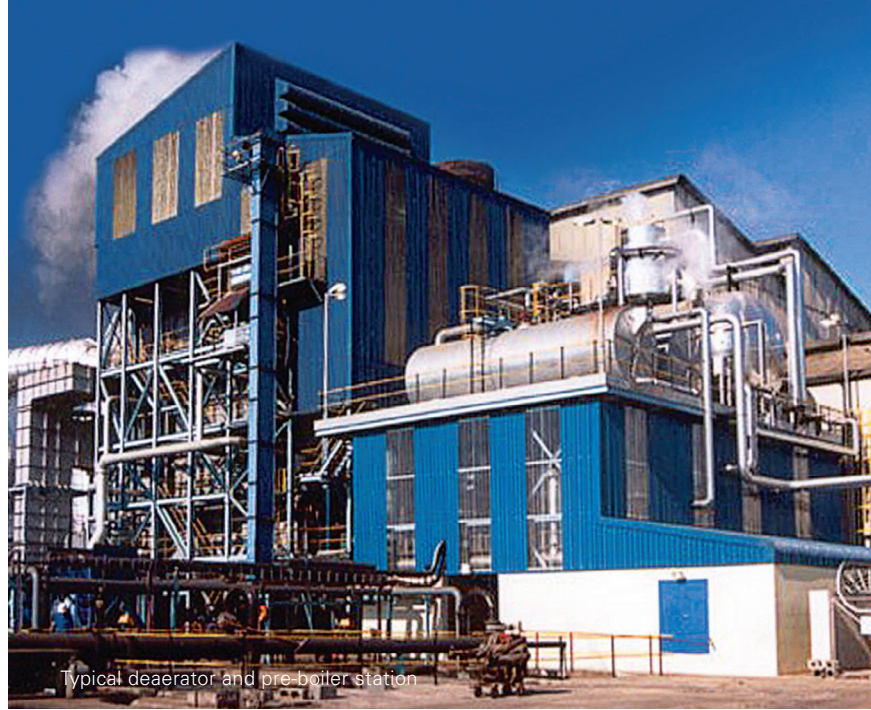

Typical deaerator and pre-boiler station

## Industrial Watertube Boilers

Our Industrial Watertube Boiler business unit designs, installs and maintains boilers and associated equipment for customers in both local and international markets. Designs for steam outputs, pressures and temperatures up to 350 t/h, 110 bar and 540 °C respectively, are available for both process steam and power generation applications. In addition, we provide a wide range of boiler and steam related services and combustion equipment for fibrous biomass-, coal-, oil- and gas-fired boilers in industries such as: sugar, food and beverage, chemical, petrochemical, steel, metallurgical, textile, pulp and paper.

### Engineering capability

Using in-house developed software and techniques, together with commercially available tools, we undertake conceptual and detailed designs, and analyses of difficult fuels, in addition to our own product development.

Our capabilities and tools include:

- Caesar II pipe stressing
- Autocad inventor for 3D modeling
- Boiler thermal modeling and design
- Portable combustion test rig to evaluate fuels

- Thermal imaging photography for combustion assessments
- Instrumentation and controls system design and implementation
- Fluent computational fluid dynamics for combustion and gas flow modeling
- Flownex for complex system problems, for example, boiler water circulation

Our boiler designs have progressed from the earlier refractory-backed hearth and self-feeding type to panelwalled units with single-pass generating banks, and more recently to the mono-drum design for high-pressure applications.

The boiler support system can be of the bottom, girth or top design depending on the specifics of the particular boiler, site conditions and customer requirements.

### Construction operations

Apart from the installation of new boilers, we undertake:

- Specialist site erection
- Lifting and rigging services
- Installation of piping, vessels and tanks
- Steelwork erection and specialist welding services



typical sugar industry boiler

### Boiler services

Our services, which can be applied to all types of boilers, furnaces, mechanical plant and associated equipment, as well as our installed footprint of over 350 watertube boilers, include:

- Efficiency tests
- Supply of OEM spares
- Metallurgical inspection
- Remnant life assessments
- Retrofits, repairs and maintenance
- Reliability studies and operational audits
- Capacity and efficiency improvements to older boilers

Based at Durban's harbour, we also service the marine industry, including general boiler maintenance and repairs.

### Product range

Our product range includes:

- Fossil- and / or biomass-fired boilers of bi-drum or mono drum design
- Travelling-grate and CAD spreader stokers
- Custom-designed AFBC and CFBC boilers
- Waste-heat recovery boilers
- Environmental equipment
- Pinhole and dump grates
- Ash handling equipment
- Combustion equipment
- Pre-boiler equipment
- Pressure vessels

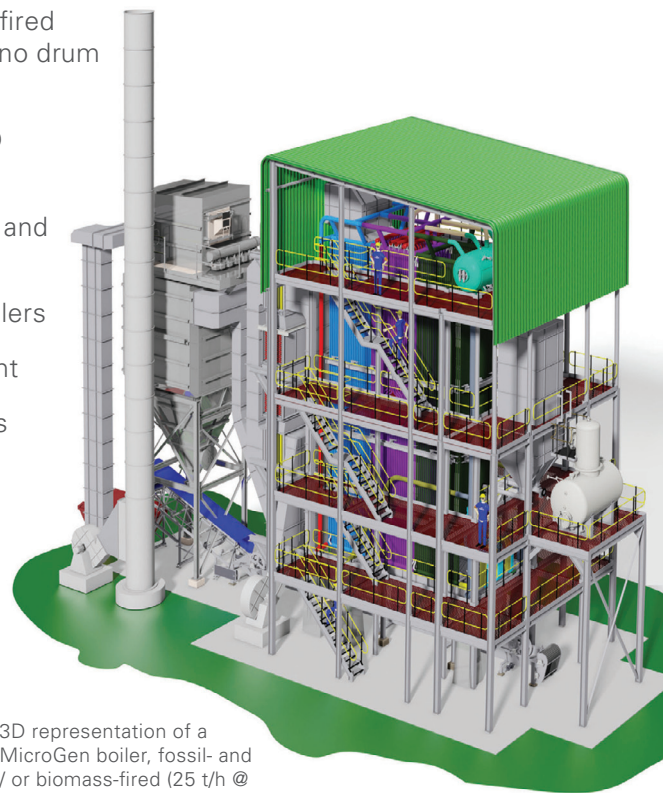

3D representation of a MicroGen boiler, fossil- and / or biomass-fired (25 t/h @ 67 bar, 485°C)



Fabric filter plant installation at a coal-fired power station

## Utility Boilers & Environmental Equipment

Our Utility Boilers and Environmental business unit provides solutions to the power generation and industrial markets. Based in Johannesburg we have a highly skilled engineering team with in-house Computational Fluid Dynamics, Finite Element Analysis, thermal and circulation modelling and solid modelling capabilities.

### Utility boilers

We are experienced in the manufacture, installation, maintenance and retrofitting of utility watertube boilers with a reference footprint covering over 25 utility boilers in local municipalities.

With workshops in Johannesburg and Cape Town, we can manufacture a wide range of utility boiler components such as superheater elements, finned economisers, tube-panels, burner tube-nests, burners, various headers and tubeshields.

In addition to boiler envelope and external piping maintenance services, we also maintain coalmilling plant, pulverised fuel systems and coarse-ash plants for the utility industry.

### Environmental equipment

We also specialise in the design, manufacture, installation and/ or retrofit and maintenance of emission

control plant for coal-fired boilers. These include fabric filter plant, electrostatic precipitators and flue-gas conditioning plants. We have retrofitted fabric filter plant on utility boilers with outputs from 200 MW to 600 MW.

### Fabrication Facility

Our Fabrication Facility located in the industrial area of Isando, Johannesburg, was established in 2011 to provide faster manufacture, refurbishment and repair services on boilers and associated plant for our Gauteng-based customers.

The facility covers an area of over 1 400 m<sup>2</sup> and includes the following sections:

- Manufacturing
- Welder Training Centre
- Non-Destructive Testing
- Welding Procedure Development

### Manufacturing equipment

The equipment installed includes:

- Plate roller for plate thicknesses up to 20 mm x 2.4 m wide
- Section roller for angle iron, flat bars, etc.
- Press brake – 250 ton, for plate up to 16 mm thick, with a knife length of 3.2 m
- Guillotine for plate up to 16 mm thick x 3 m wide
- Plasma cutter for stainless steel up to 32 mm thick

Boiler tube protection shields can be manufactured for tube outside diameters between 38 and 76 mm in the following materials:

- Grades 304, 310 & 316 stainless steel
- Carbon steel

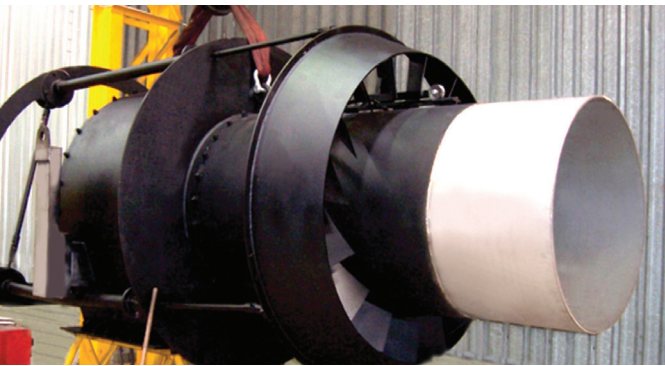

Fabrication facility

### Non-destructive testing

Our NDT includes:

- Radiography
- Wall thickness testing
- Dye penetrant inspection
- Magnetic particle inspection
- Positive material identification
- Endoscope (internal inspection)
- Hardness testing (Vickers, Brinell)
- Ultrasonic testing including phase array

All NDT procedures and specifications are Eskom approved.

### Welding

Our welding services cover:

- Procedure development
- High pressure pipe / tube welding

- Welder training and certification
- Pre- and post-weld heat treatment

The following welding processes are used:

- Flux core arc welding
- Gas metal arc welding
- Gas tungsten arc welding
- Shielded metal arc welding

All Welding Procedure Specifications (WPS) and Procedure Qualification Records conform to the requirements of EN15614 and ASME IX and have been reviewed and approved by both an Authorised Inspection Authority and an International Welding Engineer.

The current WPS and database consist of:

- 245 – BS EN 15614 Procedures
- 204 – ASME IX Procedures

### Certification

Our Isando site has been assessed and certified in accordance with the requirements of:

- ISO 9001
- ISO 14001
- OHSAS 18001



Boiler tube manipulation

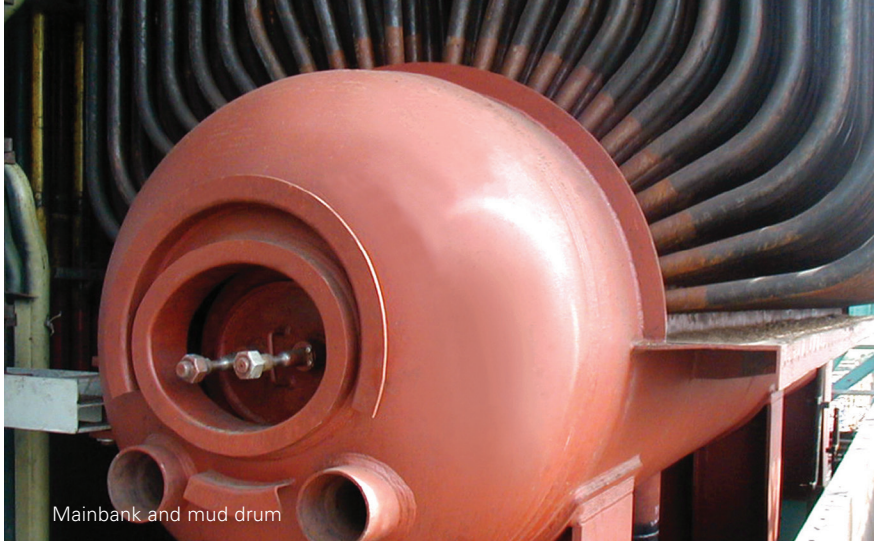

Mainbank and mud drum

# Manufacturing

## Works

Our manufacturing facility was established in 1954 and has been developed and expanded over the years to become one of the top facilities of its kind in South Africa. It has a total floor area under roof of 30 000 m<sup>2</sup> and a lifting capacity of 100 tons. We have designed and manufactured equipment in accordance with a number of international codes and specifications including: EN, ASME, BS,AD Merkblätter, ANCC and TRD.

## Inspection and testing

- X-ray
- Ultrasonic testing (UT)
- Dye penetrant inspection (DPI)
- Magnetic particle inspection (MPI)
- Hardness testing (fixed & portable)
- Tensile: bends, drift expanding, compression

## Welding

The following welding processes are in use:

- Metal active gas .....(MAG & pulsed MAG)
- Metal inert gas .....(MIG & pulsed MIG)
- Tungsten inert gas .....(TIG & pulsed TIG)
- Metal core arc welding ...(MCAW)
- Flux core arc welding .....(FCAW)
- Manual metal arc .....(MMA)
- Flash butt welding .....(FBW)
- Oxy-acetylene .....(OA)
- Submerged arc .....(SA)
- Stud welding



Waste-heat boiler



Fin-tube economiser elements

### Weld procedures

Our welding department ensure that we work to ISO 3834 and are supported by our IWE and IWT. Our weld procedures range from carbon steel to ASTM A213 T91.

### Training

We have been conducting a comprehensive apprentice training program for welders and boilermakers for the past 20 years. Our training facility, with the support of a local college, recruits students from the local community for the benefit of John Thompson, the community and local industry.

### Foundry

All castings required for our boilers and stokers can be produced in our own foundry under the Meehanite process to a guaranteed specification and quality.

### Products

Our products include steam and mud drums, pressure vessels, firetube boilers, waste-heat boilers, deaerators, autoclaves, shell and tube heat exchangers, gas cooler hoods and process equipment, as well as:

#### Headers

Primary superheater headers – carbon / 13CrMo4-5

Secondary superheater headers – carbon / 13CrMo4-5 / 10CrMo9-10

Economiser headers – carbon  
Furnace headers – carbon / 16Mo3

Mainsteam header – 13CrMo4- 5 / 10CrMo9-10

Attemporator piping – ASTM A355 P11 / ASTM A355 P22

#### Membrane panels

Panel tubing diameters range from 30 mm to 100 mm with tube pitch and thickness as specified.

### Economiser elements

Plain economiser – carbon / 16Mo3

Fin-tube economiser – carbon / 16Mo3 diameter 38 mm and 50 mm

Spiral-tube economiser – carbon / 16Mo3 diameter 38 mm and 50 mm

### Evaporator banks

Plain / finned evaporator – carbon / 16Mo3 / 13CrMo4-5

### Reheater elements

Elements c/w attachments – 13CrMo4-5 / 10CrMo9-10 / T91

### Superheater elements

Pendant / horizontal type – 13CrMo4-5 / 10CrMo9-10 / T91

### Tube Manipulations

Burner nest openings – carbon / 16Mo3



Reverse air baghouses – Ferroalloy plant

## Air Pollution Control

Our Air Pollution Control business unit offers a comprehensive range of air filtration / dust collection products and systems for emissions control, gas cleaning and product recovery. We provide a complete service of design, manufacture and installation of dust control equipment for any type of dust in industrial, mining or commercial environments.

Combined with years of application experience and global resources, our products and services include:

### Engineered systems

Complete turnkey systems design and implementation capability including:

- Start-up
- Testing
- Installation
- System design
- Process analysis
- Equipment supply

### Cyclones

High efficiency cyclones are the most cost-effective solution for separating dry particulate (5 microns or larger) from gas streams.

### Reverse air baghouses

Used primarily in combustion related applications, these collectors are very effective for various applications involving extremely fine dust with low outlet emissions.

### Wet scrubbers

We offer several configurations and a full range of sizes to meet almost any requirement:

- Packed towers
- Multi-vane scrubbers
- Multi-venturi scrubbers
- High efficiency venturi scrubbers
- Dynamic scrubbers with integral fan

### Product collection

Where product is generated in dust form our older bag filters serve as an excellent product collector.

### After sales services and spares

- Complete system evaluation
- Mechanical equipment review and evaluation
- Conversion and upgrading of equipment
- Equipment refurbishing and rebuilding
- Service / maintenance contracts
- Technical training



Reverse pulse bag filters – Copper furnace secondary fume extraction

### Reverse pulse bag filters (tubular & envelope)

The tubular reverse pulse bag filter is the most widely used, providing high efficiency collection at a constant pressure drop.

#### FM Filcomatic (cased units)

Automatic reverse pulse bag filter designed in modular format to give a compact filter for continuous operation with high dust loads and constant pressure drop. The flat

bags give maximum cloth area with minimum space and the modular construction allows accurate sizing of the filter to design air volume.

#### FMI Filcomatic (insertable)

The insertable filter is manufactured in a range of sizes from 4 to 60 m<sup>2</sup> of cloth area, with or without integral fan. The units are designed to be incorporated into other equipment such as pneumatic

conveying systems, silos, conveyor belt transfer points, mills and in fact any application where the collected dust can or needs to be returned to the process.

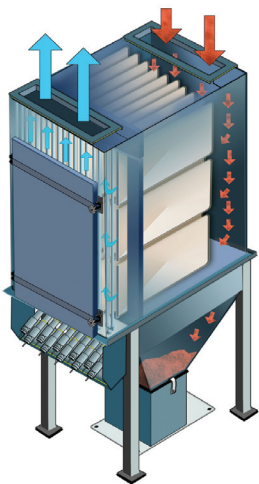

FMI Filcomatic reverse pulse bag filter

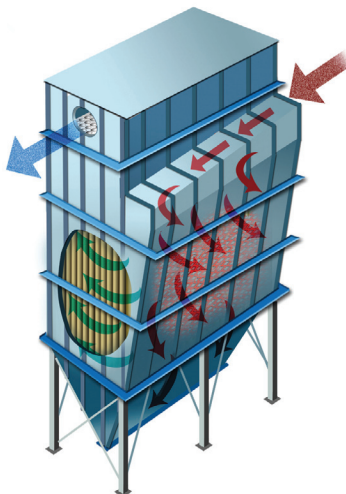

Expanded diffuser inlet

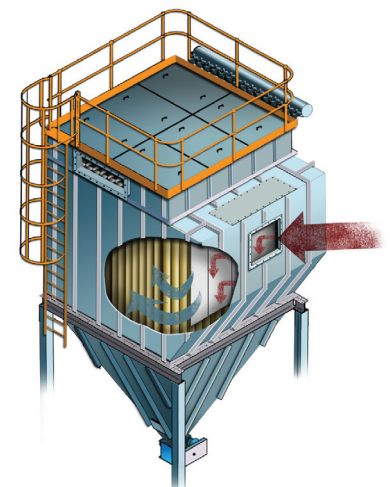

Casing baffle inlet



Coal-fired boilerhouse

## Energy Management

Our Energy Management department was formed to embrace the current worldwide trend of outsourcing non-core business. Under an energy management agreement we take responsibility for supplying energy to our customers' processes reliably, safely and efficiently.

As each plant has its own operating parameters, each agreement is tailored to satisfy individual customer needs. Energy management is therefore a partnership solution offering transfer of risk by outsourcing the supply of equipment and services to John Thompson.

### Plant operation and maintenance

The design, manufacture, operation and maintenance of energy plant and associated equipment is our business and we understand that a reliable service is critical for our customers' production requirements.

As efficient and capable operating staff are essential for a successful business we train them at our modern training centre which has a fully operational coal-fired and oil-fired boilerplant. High plant efficiencies are the result of supervised, trained operators together with our thorough understanding of equipment design.

### Outsourcing

Some reasons to outsource the supply and operation of energy plant and associated equipment include:

- Transfer of plant operation and maintenance
- Delegation of responsibility in terms of the OHS Act 85 of 1993
- Fixing operating costs to allow accurate budgeting
- Freeing-up management time for other value-adding activities
- Lower working capital costs
- Improved operating efficiency
- Improved cash flow

### Commercial

Under an energy management agreement, customers are charged monthly for the metered quantity of steam used, plus an agreed fixed cost.

This facilitates accurate budgeting of all operating costs which are made up as follows:

### Fixed cost

The fixed cost covers those costs that are unrelated to the amount of steam used such as:

- Insurance
- Capital costs
- Administration
- Salaries and wages
- Statutory inspections

### Variable cost

The variable cost covers all input costs which relate directly to the amount of steam produced such as:

- Fuel
- Water
- Electricity
- Maintenance
- Water treatment

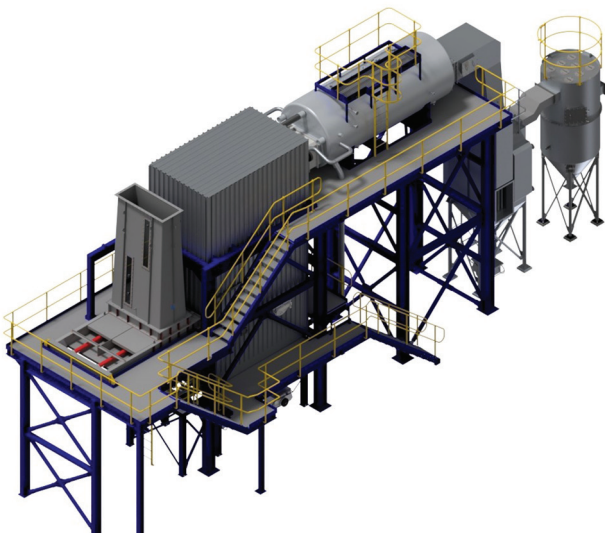

3D representation of a Torripac biomass-fired boiler

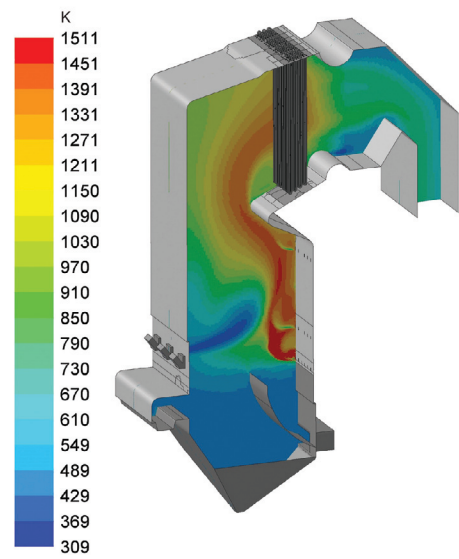

CFD results of combustion gas temperature in a watertube boiler

## Research and Development

The growing demand for a cleaner and more sustainable environment and for higher steam pressures and temperatures means that Computational Fluid Dynamics (CFD) technology is required for boiler development and design work. In addition, the combustion process inside a modern watertube boiler is a complex phenomenon consisting of numerous chemical reactions all of which play an important role in boiler performance.

### Computational fluid dynamics

CFD technology enables our engineers to model the combustion process and related physics of various fossil- and biomass-fired boilers and resolve potential design and operating problems before the manufacturing and commissioning stages.

Physics in the CFD model include:

- tracking of fuel particles
- evaporation and devolatilisation of these particles
- surface combustion on the fuel particles
- the combustion process in the gas

- radiation heat transfer
- pollution formation

A high level of geometric detail is included to capture certain key results. Geometries considered in detail are the fuel spreaders, the combustion air system and the furnace, as well as the tube banks of the various heat exchanger sections.

Results from the heat flux distribution analysis show the temperature contours, flow patterns, and gas composition throughout the boiler. This data provides a better circulation assessment of the pressure envelope and enables us to

keep improving our boiler and combustion equipment designs which are industry benchmarks.

### Torripac biomass-fired boiler

As part of ongoing development work our engineers have conducted tests firing a variety of biomass fuels on the boilers of clients who want to burn biomass as an alternative to coal, oil and gas, as well as on the boiler installed at our test centre.

This has led to the development of our Torripac biomass-fired boiler, which combines both watertube and firetube boiler technology, and is suitable for the cogeneration of process

## John Thompson Branches

### CAPE TOWN

Sacks Circle, Bellville South, 7530

P.O. Box 129, Bellville, 7535

Tel: (021) 959-8400

Fax: (021) 959-8545

info@johnthompson.co.za

### ISANDO

42 Diesel Road, Isando, 1609

P.O. Box 8382, Edenglen, 1613

Tel: (011) 392-0900

Fax: (011) 974-2695

infojhb@johnthompson.co.za

### DURBAN

4 Belfast Road, Bayhead, 4001

P.O. Box 32292, Mobeni, 4060

Tel: (031) 408-9700

Fax: (031) 408-9722

infodbn@johnthompson.co.za

### BLOEMFONTEIN

Unit A, 4 Hartley Street, Hamilton,

Bloemfontein, 9301

Tel: (051) 433-1192

Fax: 086-768-3632

infoblmlm@johnthompson.co.za

### GOEBERHA

55 Fettes Road, North End,

Gqeberha, 6001

Tel: (041) 373-0364

infope@johnthompson.co.za

### CRESTA

Cresta Junction, Block A, Cnr Beyers

Naude Drive & Judges Ave, Cresta, 2194

P.O. Box 4051, Cresta, 2118

Tel: (011) 478-0456

Fax: (011) 478-0371

infoapc@johnthompson.co.za

### DURBAN - HVAC

27-29 Circuit Road, Westmead,

Pinetown, 3600

Tel: (031) 700-3286

Fax: (031) 700-4101

infohvac@johnthompson.co.za

[www.johnthompson.co.za](http://www.johnthompson.co.za)

